



VIDAR NDT*PRO* **Industrial Film Digitizer**

Installation Guide
For Use with Windows 7 & Windows 8
(Serial Numbers 370,000 to 379,999)



© Copyright 2017 by VIDAR® Systems Corporation. All rights reserved.

Terms denoted by the trademark symbol (™ or ®) used in this publication are trademarks or service marks registered in the United States or other countries.



365 Herndon Parkway
Herndon, VA 20170 U.S.A.

Phone: 1-703-471-7070
Fax: 1-703-471-7665
Internet: www.vidar.com

Sales: 1-800-471-7226
Email: order@3dsystems.com

Technical Support:
Phone: 1-800-471-SCAN or 1-703-471-7070
E-mail: medtech@3dsystems.com

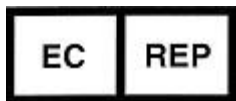

Emergo Europe
Prinsessegracht 20
2514 AP The Hague
The Netherlands

E-mail: europe@emergogroup.com

Caution: No operator-serviceable parts inside. Refer servicing to qualified personnel.
Achtung: Gehäuse nicht öffnen. Wartung und Reparatur nur durch Elektrofachkräfte.
Attention: Aucune pièce ne peut être remplacée par l'utilisateur. Toute opération de maintenance doit être effectuée par une personne qualifiée.
Atencion: Acceso interno solo autorizado a personal técnico cualificado.
Attenzione: Non aprire. Rivolgersi a personale qualificato.

Radio Frequency Emissions

This equipment has been tested and found to comply with the limits for a Class A digital device, pursuant to Part 15 of the FCC Rules. These limits are designed to provide reasonable protection against harmful interference when the equipment is operated in a commercial environment. This equipment generates, uses, and can radiate radio frequency energy and, if not installed and used in accordance with the instruction manual, may cause harmful interference to radio communications. Operation of this equipment in a residential area can cause harmful interference, in which case the user will be required to correct the interference at his or her own expense.

Product compliance testing was conducted using VIDAR shielded cables. Modifications to the digitizer or the VIDAR shielded cables or the use of cables other than those available from VIDAR could void the user's authority to operate the equipment.

Acceptable shipping conditions

- Temperature: -18° to $+60^{\circ}\text{C}$ (0° to $+140^{\circ}\text{F}$)
- Relative humidity: 20% to 85%, non-condensing
- Atmospheric pressure: 500 to 106 hPa (+18,000 to $-1,200\text{ft}$)

Operating conditions

- Temperature: 10°C to 30°C (60°F to 85°F)
- Relative humidity: 20% to 85%, non-condensing
- Atmospheric pressure: 696 to 1013 hPa (10,000 to 0 ft)

Electrical supply

- Voltage: 100 to 240 VAC
- Current: 0.75 to 1.5 A
- Frequency: 47 to 63 Hz

Safety and compliance information



MEDICAL EQUIPMENT WITH RESPECT TO ELECTRIC SHOCK, FIRE AND MECHANICAL HAZARDS ONLY IN ACCORDANCE WITH UL60601-1, IEC60601-1 AND CAN/CSA C22.2 No. 601.1



This product is intended to be turned on and left on. Operation is continuous. To maintain Medical Equipment Certification, the digitizer must be connected to a host computer that has been configured in accordance with IEC 60601-1-1.

This product is in the Ordinary Equipment Class. It provides no protection against the ingress of water.

This product is not suitable for use in the presence of flammable anesthetic mixtures with air or with oxygen or with nitrous oxide.

Class I Medical Device; No Applied Parts. This product provides Class I medical device protection against electrical shock.

Power cords used with this device in North America must be rated by Underwriters Laboratories for hospital use. Power cords used with this device in Europe must meet the requirements of IEC 227 Designation 53 or IEC 245 Designation 53.

Correct and safe operation of the digitizer requires familiarity with information that is not marked on the product. The following symbol indicates the operator should consult the manual for additional information.



This Class 1 LED device is safe under reasonably foreseeable conditions of operation.

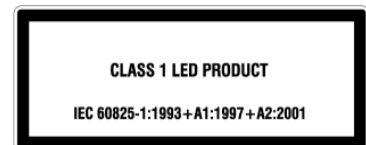

The LED illumination system consists of 16 Class 1 LEDs, a mirror system to spread the light, and a diffuser to distribute the light approximately uniformly across an area of 2.4 sq in (15.5 sq cm). Light from the LED illuminator may be indirectly observed in the digitizer's film entry and exit areas.

Contents

VIDAR NDT<i>PRO</i> Industrial Film Digitizer Installation Guide	1
Intended Use	6
Unpack	7
1. Look for Damage.....	7
2. Unpack the shipping carton	8
3. Unpack the Accessory Box.....	9
4. Unwrap.....	10
5. Identify the Components	11
6. If Anything Is Missing.....	12
7. Activate Your Product Warranty.....	12
Setting Up	13
Identify Important Features	14
Assemble the Digitizer	15
Connect the Power Cord.....	20
VIDAR NDT<i>PRO</i> Industrial Film Digitizer Device Driver Installation Guide	21
Install Device Drivers for Windows 7 & 8	22
1. Apply Power to the Digitizer.....	22
About the VIDAR Drivers	23
2. Install the VIDAR Drivers	23
Appendix: Electromagnetic Guidance	29
Appendix: Symbols	33

Intended Use

The *NDTPRO* Industrial Film Digitizer is intended for making digital copies of x-ray films for non-destructive testing applications. This device is not intended for medical use.

Unpack

In this chapter, you will:

- Unpack and inspect the digitizer's parts.
- Identify the digitizer's parts.

1. Look for Damage

Before unpacking the Digitizer, examine the shipping carton for damage.

If the carton is damaged:

- Notify the shipper immediately.
- Take photographs of the damage.
- Send pictures and description of damage to: medtech@3dsystems.com.
- Notify VIDAR Support at 1-703-471-7070.

2. Unpack the shipping carton

IMPORTANT: Save all the packing materials. If you need to ship the digitizer later, you should repack the digitizer in the original materials by reversing the procedure described here. Failure to properly pack, or failure to use VIDAR authorized shipping materials, will void the product's warranty, and will likely result in costly repairs.

Remove items from the shipping carton in the order shown below.

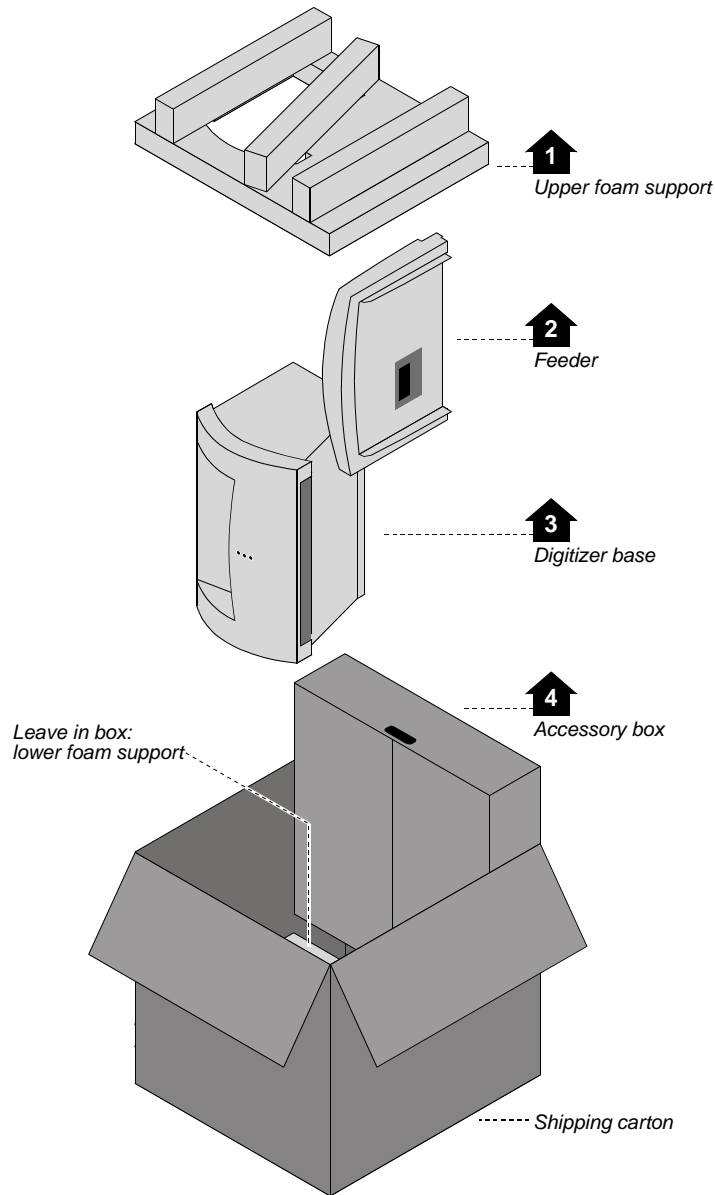

Note: For clarity, this illustration does not show the plastic bags surrounding the digitizer and feeder.

IMPORTANT: Save all the packing materials. If you need to ship the digitizer later, you should repack the digitizer in the original materials by reversing the procedure described here. Failure to properly pack, or failure to use VIDAR authorized shipping materials, will void the product's warranty, and will likely result in costly repairs.

3. Unpack the Accessory Box

a. Remove these items from the accessory box:

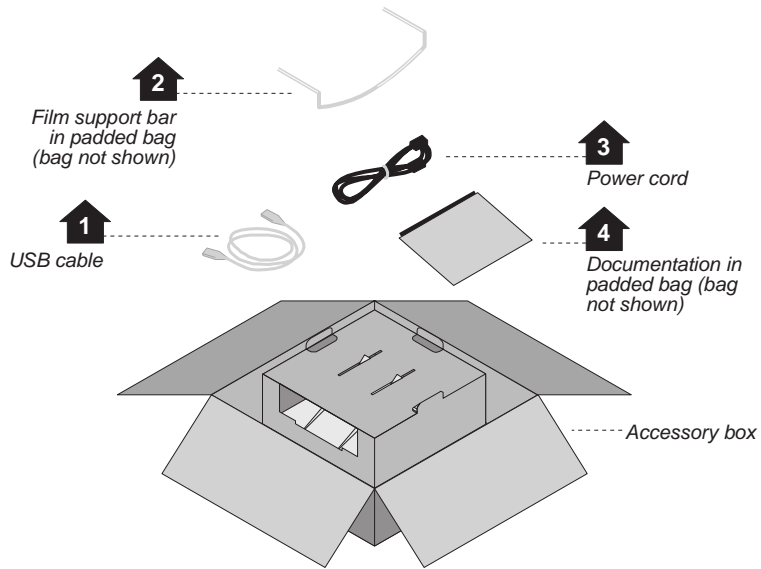

b. Then remove these items from the accessory box:

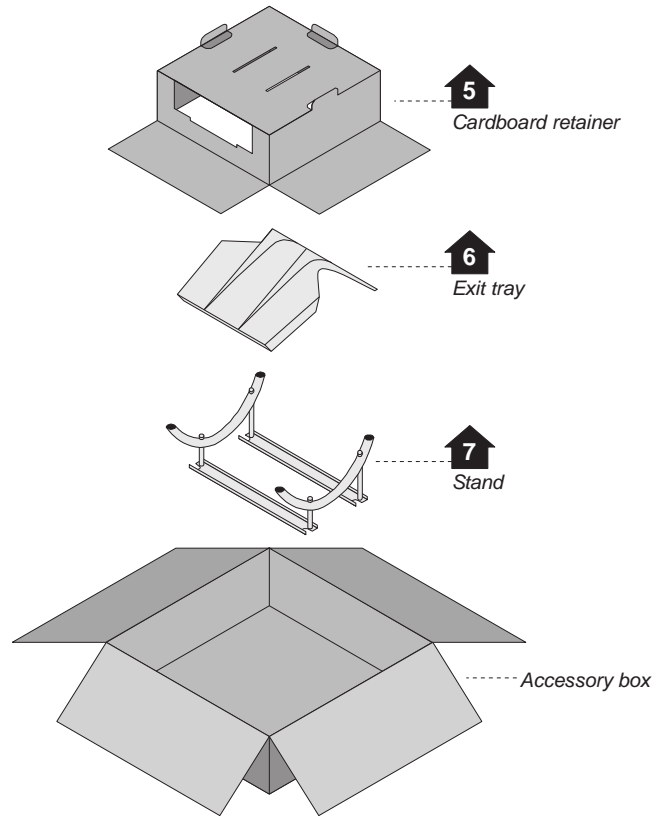

Note: For clarity, this illustration does not show the plastic bag surrounding the exit tray.

4. Unwrap

a. Unwrap all items.

b. Remove the foam block from the rear of the digitizer base:

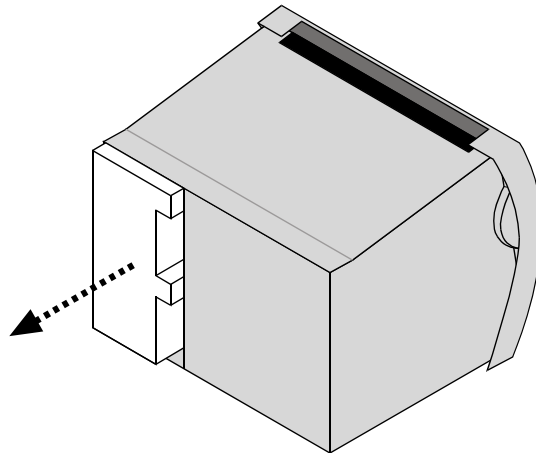

IMPORTANT: Save the carton and all packing materials. If you need to ship the digitizer later, you **must** repack it using the original wire ties, plastic bags, foam supports and cartons. Instructions for repacking are provided in the “Packing the film digitizer for shipment” section of this manual.

5. Identify the Components

✓	Item
<input type="checkbox"/>	Digitizer base
<input type="checkbox"/>	Exit tray
<input type="checkbox"/>	Film feeder
<input type="checkbox"/>	Film support bar
<input type="checkbox"/>	Stand
<input type="checkbox"/>	Power cord: 115V (p/n 4043-001) or 230V (p/n 2104-006)
<input type="checkbox"/>	Quick setup card
<input type="checkbox"/>	USB cable: 6 foot (p/n 4618)
<input type="checkbox"/>	VIDAR NDTPRO Industrial Film Digitizer CD



Digitizer Base



Exit Tray



Film Support bar



Stand



Film Feeder

6. If Anything Is Missing...

Immediately contact your VIDAR supplier.

7. Activate Your Product Warranty

- a. Locate the “Warranty information card” form on the **NDTPRO Industrial Film Digitizer CD**.
- b. Print the “Warranty information card.”
- c. In the “Product information” section, record this information:
 - Digitizer serial number.
- d. Complete the form.
- e. Mail or fax the form to VIDAR Systems Corp.

If your digitizer needs service, this information should be on file at VIDAR.

Contact VIDAR Technical Support if you have any questions about installing or using your VIDAR film digitizer:
Phone: +1.800.471.SCAN (+1.800.471.7226)
+1.703.471.7070 outside the U.S.
E-mail: medtech@3dsystems.com

NEXT: Go to “Setting up” ⇨

Setting Up

The digitizer must be placed on a counter or tabletop.

SAFETY WARNING
Never place the digitizer on the floor.

Do not place digitizer on floor!

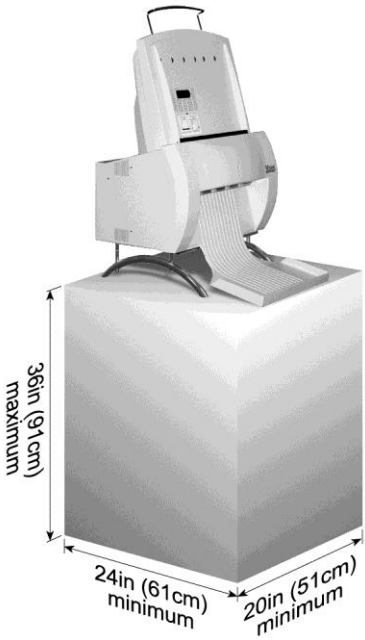

Identify Important Features

Look over the digitizer base and locate the features shown in this section. You will need to know where these features are when you assemble the digitizer.

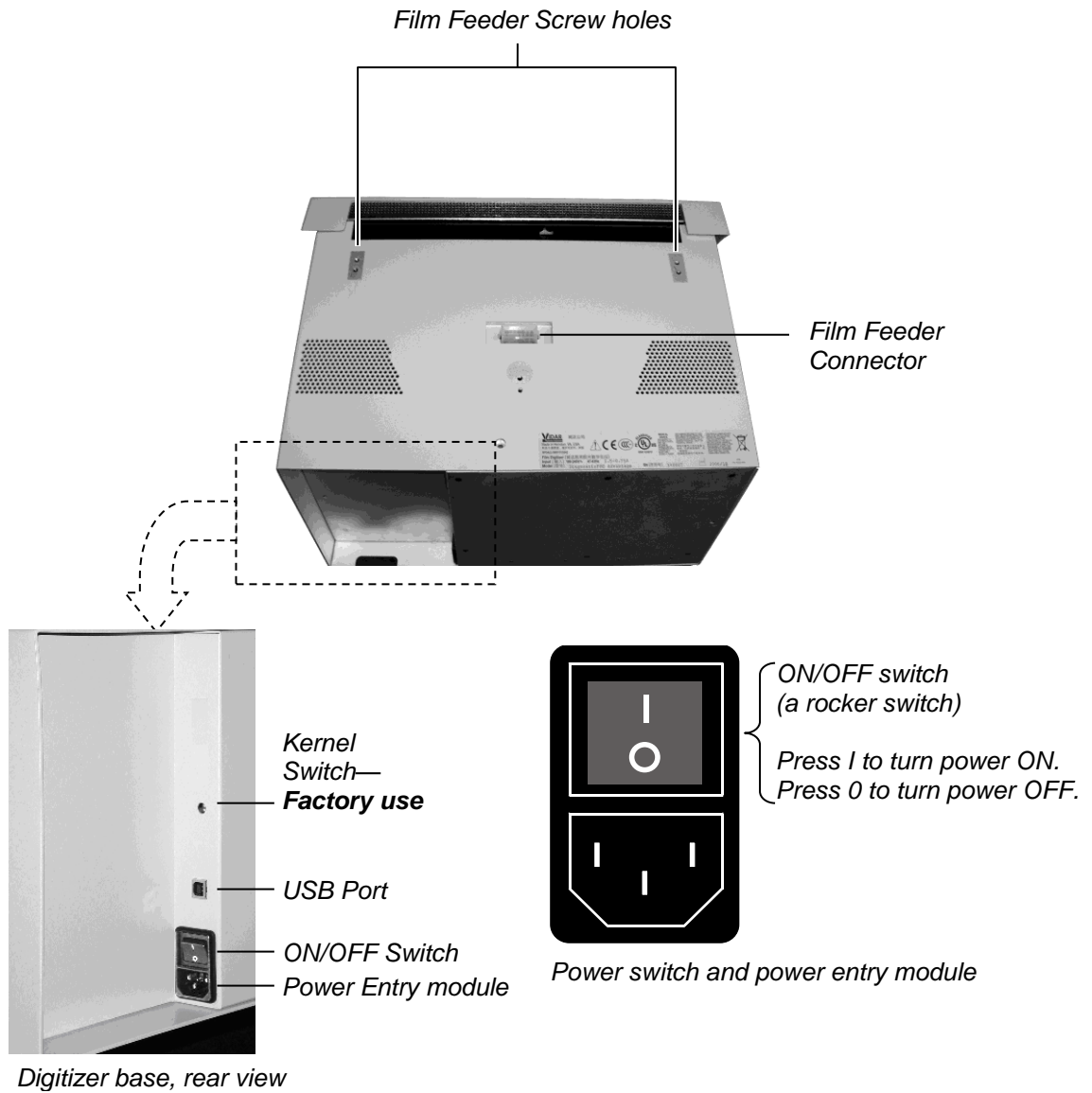

Assemble the Digitizer

1. Place the stand on a solid, flat surface (such as a table).
2. Place the digitizer base on the stand as shown below. Tighten the thumbscrews on the bottom of the stand to secure it to the digitizer.

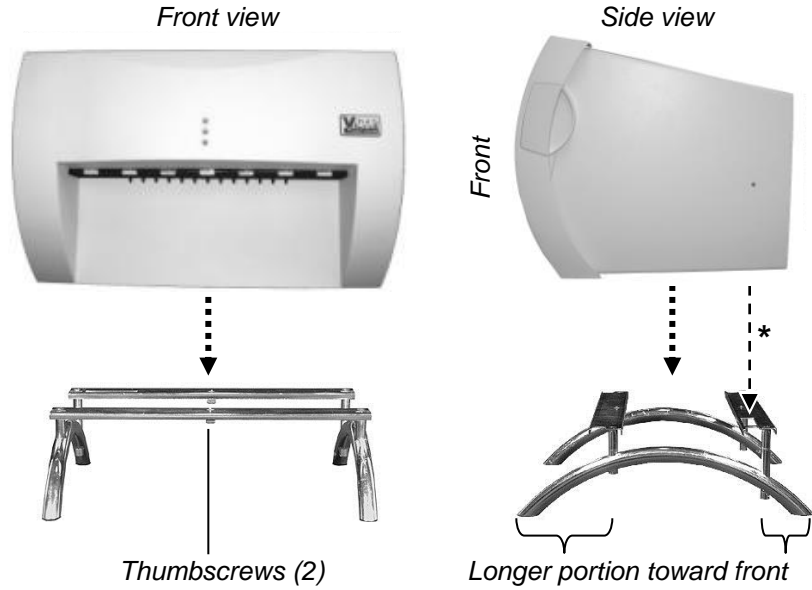

3. Attach the feeder to the digitizer:

- a. Note the three screws protruding from the bottom of the feeder. These mate to holes in the digitizer base. Two of the screws are very long—their tops ends are near the top of the feeder.

Also note the connector on the bottom of the feeder. It mates to the connector on top of the digitizer base.

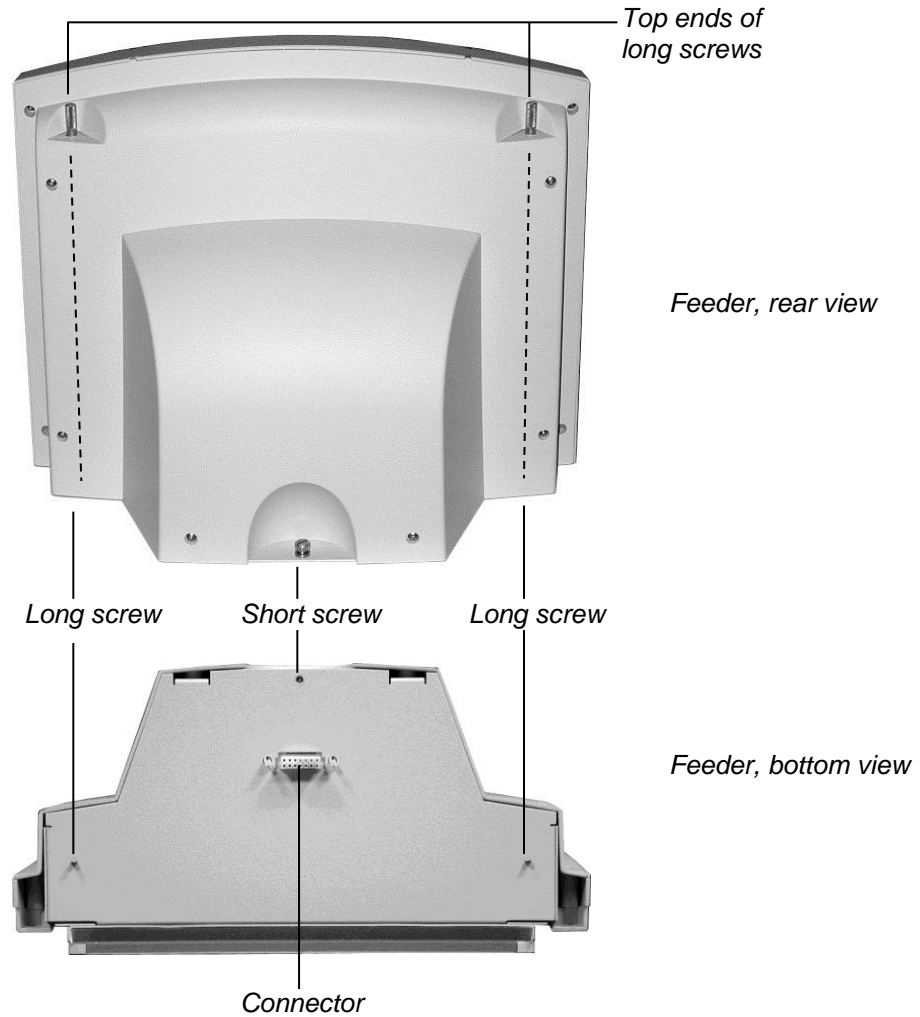

- b. Place the feeder on top of the digitizer, and slide the feeder connector into the digitizer connector.

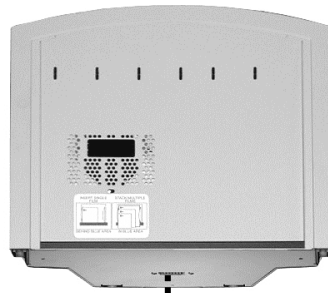

- c. On the rear of the feeder, tighten the three screws to secure the feeder to the digitizer base.

Screws

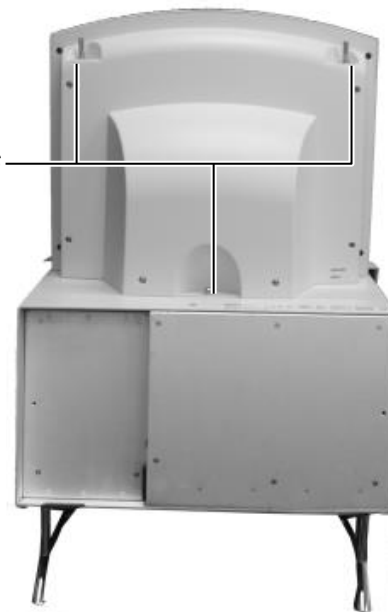

- You may need to move the feeder slightly to get the screws started in the holes.
- Tighten each screw a few turns, then repeat until all are finger tight.

4. Install the exit tray by hooking it over the notched plastic edge just below the rollers. When the exit tray is properly positioned, it will be parallel to the roller shaft.

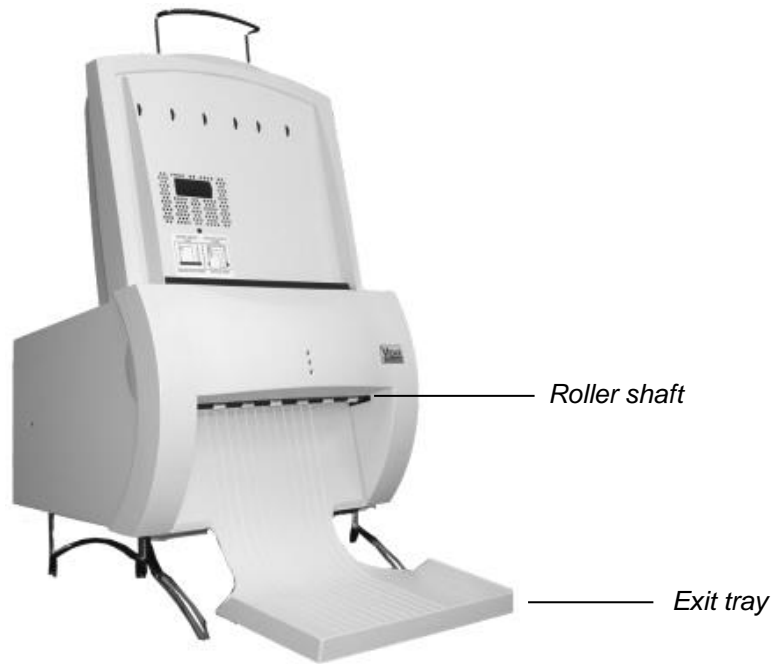

Properly installed exit tray

5. Insert the film support bar legs into the two holes on the film feeder's top edge. The film support bar's curved center portion must face the front of the film feeder.

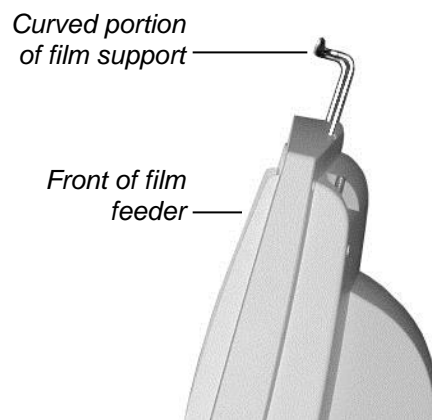
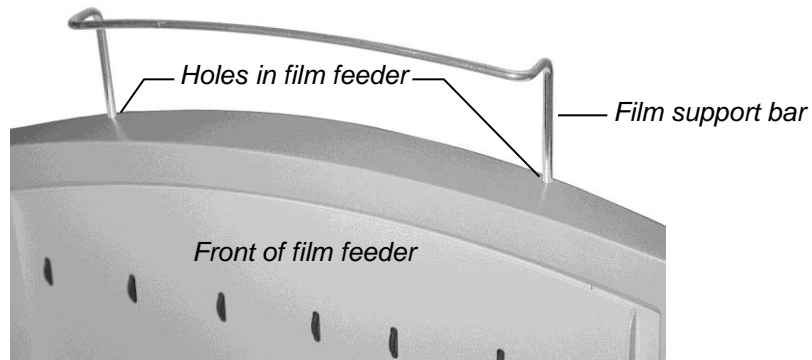

IMPORTANT: Do not lift or carry the digitizer using the film support bar.

Warning

Before you begin the installation procedure, turn off all power to the computer and peripherals.

Précaution

Avant de commencer la connexion, assurez vous que votre ordinateur soit bien éteint.

Advertencia

Antes de continuar con la instalación, favor de apagar su computadora y periférico.

Warnung

Vor dem Installieren den Computer und angeschlossene Geräte ausschalten.

Connect the Power Cord

1. Connect the power cord to the digitizer's Power Entry Module (PEM), located on the rear of the digitizer.



2. Connect the other end of the power cord to a grounded power outlet.

Note: The film digitizer has an auto-sensing power supply. When you apply power, the digitizer will detect the voltage and set itself for proper operation.

NEXT: “Device Driver Installation Guide” ➡

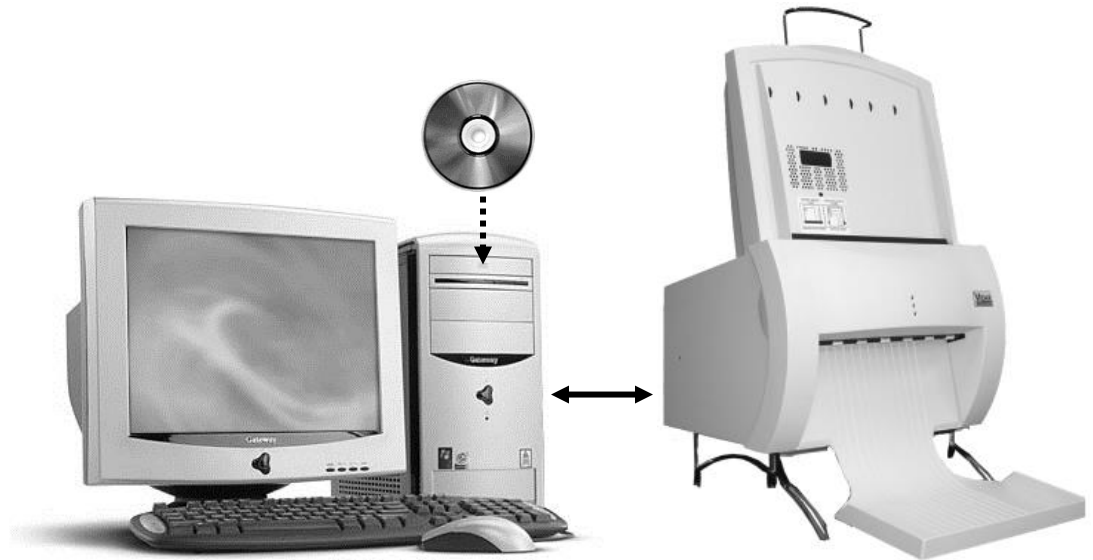

VIDAR *NDT*PRO Industrial Film Digitizer

Device Driver Installation Guide



Install Device Drivers for Windows 7 and 8

The USB driver is required for all installations to assure that the computer communicates with the digitizer.

1. Apply Power to the Digitizer

- a. Ensure the PC is turned **off**.

Note: Always turn on the digitizer before turning on the computer. This enables the computer to recognize the digitizer.

- b. Turn on the digitizer. The on/off switch is located on the back of the digitizer.



Digitizer base, rear view

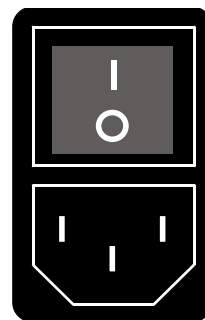

*ON/OFF switch
(a rocker switch)
Press 1 to turn power ON.
Press 0 to turn power OFF.*

Power switch and power entry module

- c. Wait for all three LEDs on the front of the digitizer to turn green.

About the VIDAR Drivers

The VIDAR driver was designed to provide compatibility between VIDAR *NDTPRO* Digitizers and Windows 8 & 7 (both 32-bit and 64-bit). Features of this driver include:

- Installation/setup wizard for easy and consistent installation.

2. Install the VIDAR Drivers

Note: The computer must be running Windows 7 & 8 Professional 32-bit or 64-bit.

Note: These instructions have been successfully tested on a wide range of Windows 7 & 8 systems. In rare instances, you may have difficulty installing the VIDAR driver. If that happens, try again after logging on as Administrator, or as a user with Administrator rights.

You will need the **VIDAR *NDTPRO* Industrial Film Digitizer CD**.

- a. Be sure the digitizer is turned ON and all three LEDs are green, but that it is NOT connected to the PC. Wait until you are prompted to connect the digitizer to the PC.
- b. Turn on the PC.
- c. Insert the **VIDAR *NDTPRO* Industrial Film Digitizer CD** into the CD-ROM drive. Browse to the CD and double-click on *19090-003 VIDAR_Driver_6.1 Online Install Package.exe* on the CD to install the driver.

d. In the first screen, click **Next >**.

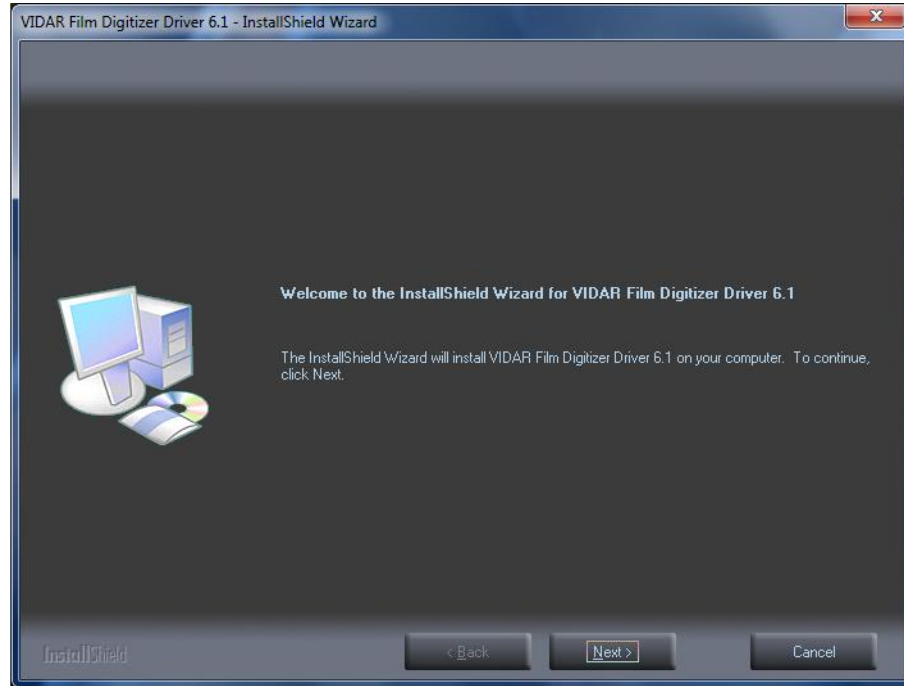

e. In the **License Agreement** screen, activate **I accept the terms of the license agreement**, then click **Next >**.

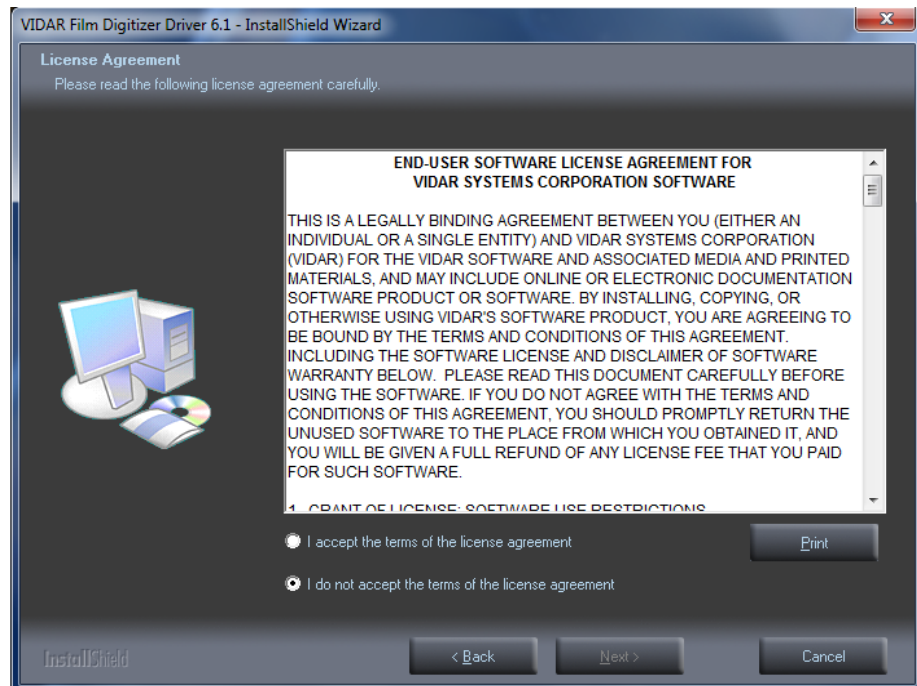

- f. In the **Ready to Install the Program** screen, click **Install**.

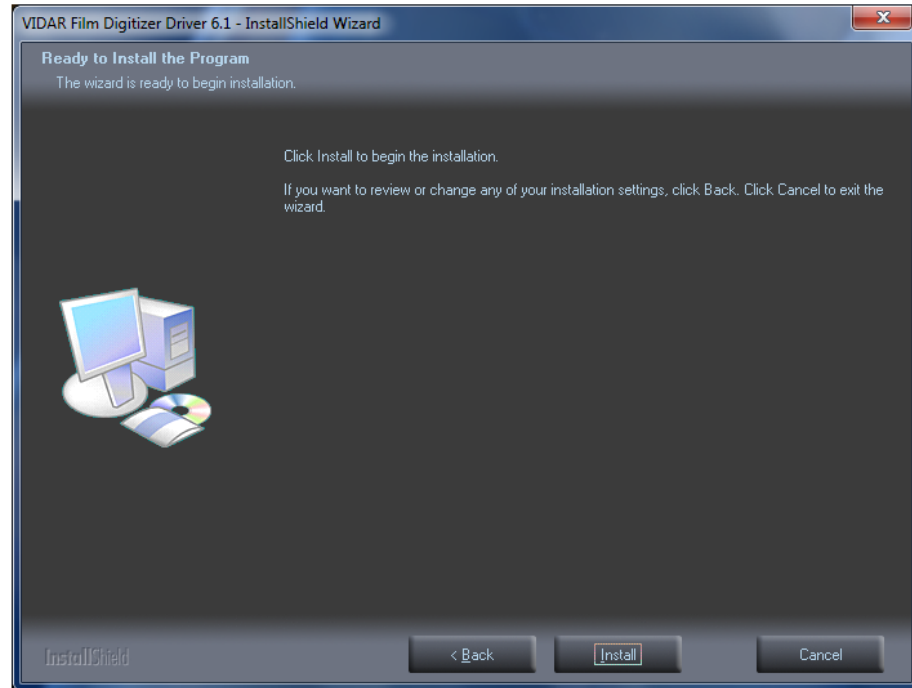

- g. The **Setup Status** screen will appear. Wait while the files are installed.

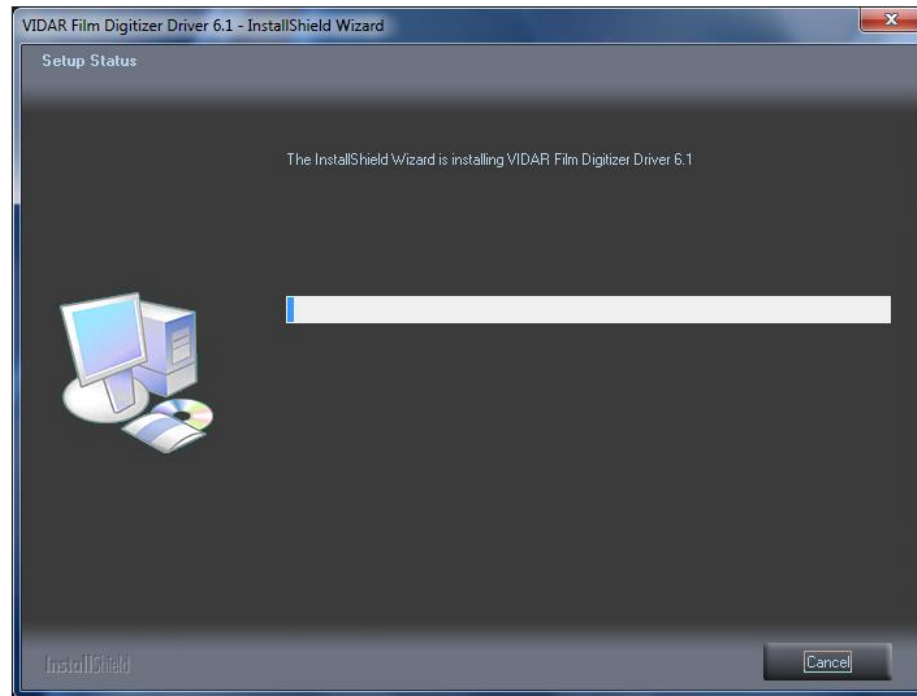

- h. When prompted “**Would you like to install this device software?**” Click **Install**. When installing on Windows 7 & 8 64 bit the name will appear as **Jungo**

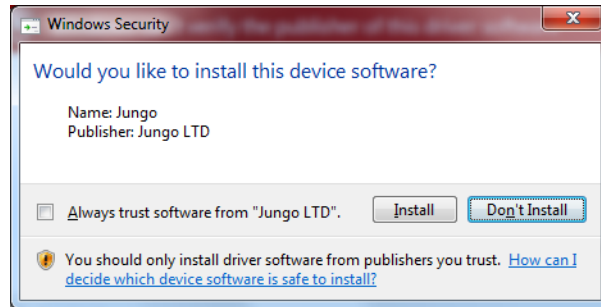

- i. When installing on Windows 7 & 8 32 Bit the name will appear as **VIDAR**

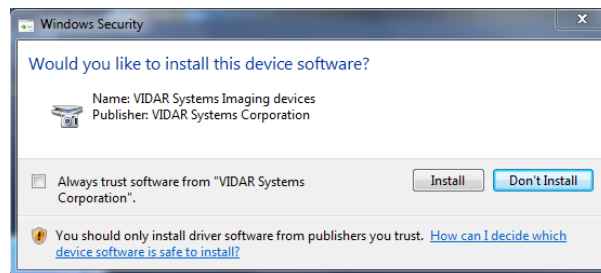

- j. InstallShield will indicate that installation is complete. However, the driver installation is not complete.

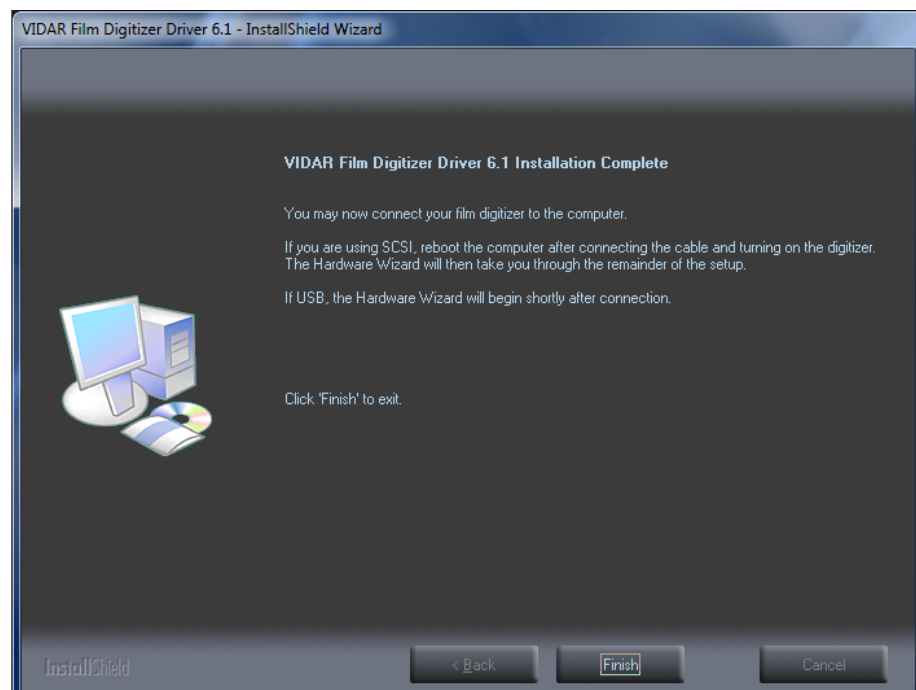

- k. Earlier, you connected a USB cable to the digitizer. Now, attach the connector on the other end of that cable to a USB 2.0 port on the computer.

Note: Wait 30 seconds after you connect the digitizer before you launch the VIDARInfo program. This ensures the computer has recognized the new hardware and has installed the driver properly.

- l. On the desktop, double-click the **VIDARINFO** icon.



- m. The window shown below will appear. This indicates that the digitizer is communicating with the computer.

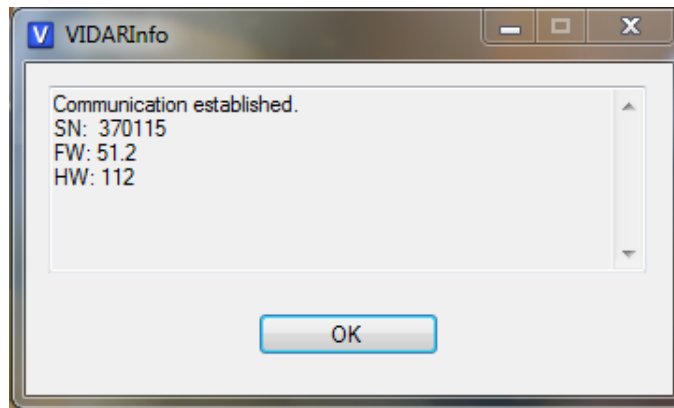

- n. Click "OK" if the Digitizer Information is present on the Screen.

The digitizer is now ready to operate. Please refer to the "User's Guide for VIDAR NDTPRO Digitizers" found on the **VIDAR NDTPRO Industrial Film Digitizer CD** for operating instructions.

You may need to install other scanning application software to run the digitizer.

Note: While the digitizer works with both 32-bit and 64-bit versions of Windows 7 & 8, it only works with 32-bit image processing applications.

- o. Additional communication testing can be found on the next page if VIDARInfo does not properly populate as expected above.

In the **Computer Management** window, the digitizer is listed under different name depending on the Bit of the OS.

When using Window 7 & 8 64 Bit OS the Digitizer is listed under **Jungo**

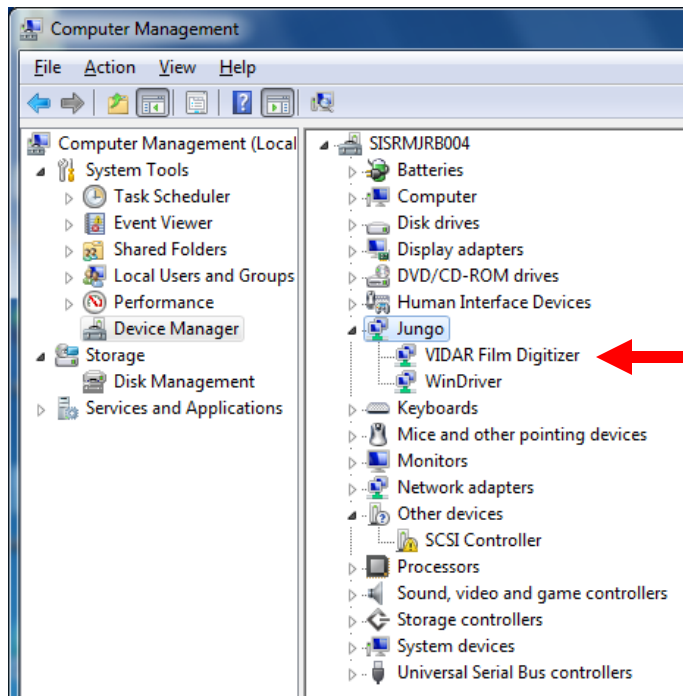

When using Window 7 & 8 32 Bit OS the Digitizer will be listed under **Imaging Devices**

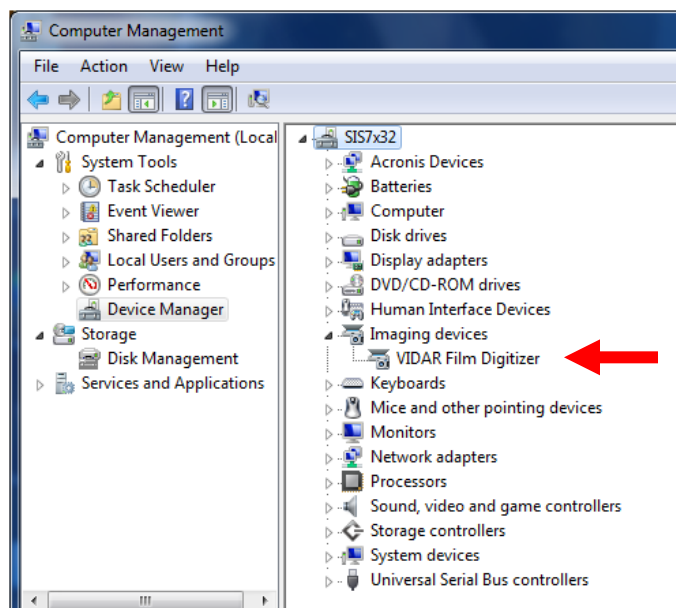

Appendix:

Electromagnetic Guidance

<p>Caution: Medical electrical equipment. EMC (Electro Magnetic Compatibility) must be considered before any medical electrical equipment is installed or put into service. Follow the information in the accompanying documentation when installing and operating the VIDAR Digitizer.</p>
<p>Caution: Portable or mobile RF communication equipment can effect Medical Electrical equipment.</p>
<p>Caution: Using the Digitizer adjacent to or stacked with other equipment may cause interference between the equipment. Before utilizing stacked or adjacent equipment, verify proper functionality of all equipment in the actual configuration in which it will operate.</p>
<p>Caution: Connecting the Digitizer to equipment that is not rated CISPR 11 class A or class B may alter the electromagnetic characteristics.</p>
<p>Caution: In a domestic environment this product may cause radio interference in which case the user may be required to take adequate measures.</p>

Guidance and manufacturer's declaration – electromagnetic equipment

Table 201

The VIDAR NDT^{PRO} Industrial Film Digitizer is intended for use in the electromagnetic environment specified below. The customer or end user of the Digitizer should assure that it is used in such an environment.

Emissions test	Compliance	Electromagnetic environment - guidance
RF Emissions CISPR11	Group 1	The Digitizer uses RF energy only for its internal functions. Therefore, its RF emissions are very low and are not likely to cause any interference in nearby electronic equipment.
RF Emissions, CISPR11	Class A	The Digitizer is suitable for use in all establishments other than domestic and those directly connected to the public low voltage power supply network that supplies buildings used for domestic purposes.
Harmonic Emissions IEC 61000-3-2	Class A	
Voltage Fluctuations/ flicker emissions IEC 61000-3-3	Complies	

Guidance And Manufacturer's Declaration – Electromagnetic Immunity

Table 202

The VIDAR NDTPRO Industrial Film Digitizer is intended for use in the electromagnetic environment specified below. The customer or end user of the Digitizer should assure that it is used in such an environment.

Immunity test	IEC 60601 test level	Compliance level	Electromagnetic environment - guidance
ElectroStatic Discharge (ESD) IEC 61000-4-2	+ 6 kV contact + 8 kV air	+ 6 kV contact + 8 kV air	Floors should be wood, concrete or ceramic tile. If floors are covered with synthetic material, the relative humidity should be at least 30%
Electrical fast transient/burst IEC 61000-4-4	±2 kV for power supply lines ±1 kV for input/output lines	±2 kV for power supply lines ±1 kV for input/output lines	Mains power quality should be that of a typical commercial or hospital environment.
Surge IEC 61000-4-5	±1 kV differential mode ±2 kV common mode	±1 kV differential mode ±2 kV common mode	Mains power quality should be that of a typical commercial or hospital environment.
Voltage dips, short interruptions and voltage variations on power supply input lines IEC 61000-4-11	<5 % U_T (>95 % dip in U_T) for 0,5 cycle 40 % U_T (60 % dip in U_T) for 5 cycles 70 % U_T (30 % dip in U_T) for 25 cycles <5 % U_T (>95 % dip in U_T) for 5 sec	<5 % U_T (>95 % dip in U_T) for 0,5 cycle 40 % U_T (60 % dip in U_T) for 5 cycles 70 % U_T (30 % dip in U_T) for 25 cycles <5 % U_T (>95 % dip in U_T) for 5 sec	Mains power quality should be that of a typical commercial or hospital environment. If the user of the Digitizer requires continued operation during power mains interruptions, it is recommended that the Digitizer be powered from an uninterruptible power supply or a battery
Power frequency (50/60 Hz) magnetic field IEC 61000-4-8	3 A/m	3 A/m	Power frequency magnetic fields should be at levels characteristic of a typical location in a typical commercial or hospital environment.

NOTE: U_T is the A.C. mains voltage prior to application of the test level

Guidance And Manufacturer's Declaration – Electromagnetic Immunity

Table 204

The VIDAR NDTPRO Industrial Film Digitizer is intended for use in the electromagnetic environment specified below. The customer or end user of the Digitizer should assure that it is used in such an environment.

Immunity test	IEC 60601 test level	Compliance level	Electromagnetic environment - guidance
Conducted RF IEC 61000-4-6	3 Vrms 150 kHz to 80 MHz	3 V	Portable and mobile RF communication equipment should be used no closer to any part of the Digitizer, including cables, than the recommended separation distance calculated from the equation applicable to the frequency of the transmitter. Recommended separation distance $d = 1.2\sqrt{P}$
Radiated RF IEC 61000-4-3	3 V/m 80 MHz to 2,5 GHz	3 V/m	$d = 1.2\sqrt{P}$ 80 MHz to 800 MHz $d = 2.3\sqrt{P}$ 800 MHz to 2.5 GHz Where P is the maximum output power rating of the transmitter in watts (W) according to the transmitter manufacturer and d is the recommended separation distance in meters (m). Field strengths from fixed RF transmitters, as determined by an electromagnetic site survey, ^a should be less than the compliance level in each frequency range. ^b Interference may occur in the vicinity of equipment marked with the following symbol: 

Note 1: At 80MHz and 800MHz, the higher frequency range applies.

Note 2: These guidelines may not be applicable in all situations. Electromagnetic propagation is affected by absorption and reflection from structures, objects and people.

^a Field strengths from fixed transmitters, such as base stations for radio (cellular/cordless) telephones and land mobile radios, amateur radio, AM and FM radio broadcast and TV broadcast cannot be predicted theoretically with accuracy. To assess the electromagnetic environment due to fixed RF transmitters, an electromagnetic site survey should be considered. If the measured field strength in the location in which the Digitizer is used exceeds the applicable RF compliance level above, the Digitizer should be observed to verify normal operation. If abnormal performance is observed, additional measures may be necessary, such as reorienting or relocating the Digitizer.

^b Over the frequency range 150 kHz to 80 MHz, field strengths should be less than 3 V/m.

Rated maximum output power of transmitter W	Separation distance according to frequency of transmitter, m		
	150 kHz to 80 MHz $d = 1.2\sqrt{P}$	80 MHz to 800 MHz $d = 1.2\sqrt{P}$	800 MHz to 2.5 GHz $d = 2.3\sqrt{P}$
0.01	0.12	0.12	0.23
0.1	0.37	0.37	0.74
1	1.2	1.2	2.3
10	3.7	3.7	7.4
100	12	12	23





For transmitters rated at a maximum output power not listed above, the recommended separation distance d in meters (m) can be estimated using the equation applicable to the frequency of the transmitter, where P is the maximum output power rating of the transmitter in watts (W) according to the transmitter manufacturer.

NOTE 1: At 80 MHz and 800 MHz, the separation distance for the higher frequency range applies.

NOTE 2: These guidelines may not apply in all situations. Electromagnetic propagation is affected by absorption and reflection from structures, objects and people.

Appendix:

Symbols

Symbol	Description
	Caution – See instructions for use
	Underwriters Laboratories listing symbol
	Compliance to EU Directives
	Authorized Representative in the European Community
	This symbol on the product indicates that this product must not be disposed of as unsorted municipal waste. Instead it is your responsibility to dispose of your waste electrical and electronic equipment by handing it over to a designated collection point for recycling of waste electrical and electronic equipment. For more information about where you can dispose of your waste equipment for recycling please contact your local city office, your household waste disposal service or the shop where you purchased the product.



VIDAR

systems corporation

A 3D Systems Company

365 Herndon Parkway

Phone:

Fax:

Web:

Herndon, VA 20170

+1.703.471.7070

+1.703.471.7665

www.vidar.com

Technical Support:

Phone:

Email:

+1.703.471.7070

+1.800.471.7226

+1.703.471.7665

medtech@3dsystems.com

